

TimeSource® 3600

GPS Stratum 1 Timing System



Key Features

- Expandable outputs provides single box solutions for small/remote offices
- Built-in early warning performance monitoring catches problems before they impact the network
- Optional NTP TimeServer
- Eight user-configurable T1/E1/2.048 MHz outputs
- Sync status messaging

Key Benefits

- Increases sync coverage into harsh GPS environments
- Window antenna lowers installation and maintenance costs
- Extended holdover reduces nuisance alarms and downtime
- Economical PRS alternative to cesium

The Symmetricom® TimeSource® 3600 is a standalone Stratum 1 Primary Reference Source (PRS) which works in GPS hostile environments. TimeSource 3600 meets ITU-T G.811 network PRS performance requirements inside a building using an antenna mounted inside a window or on an outside wall. Timing outputs with Stratum 1 performance are achieved using advanced BesTime® technology, single-satellite-locking GPS receiver subsystem, and Rubidium local oscillator.

BesTime is a flexible clock engine which provides robust performance in compromised GPS installations. BesTime continues to predict GPS timing information during the loss of GPS signals thereby guaranteeing Stratum 1 performance with as few as one satellite in view for as little as 10 hours per day. PRS quality holdover is extended to 72 hours for long term GPS outages. Typical holdover performance is three weeks at PRS quality (at 25° C). TimeSource 3600 can be installed in just about any window with a view to the sky, making it an inexpensive, yet high performance, alternative to cesium.

Configuration Options

The TimeSource 3600 comes standard with two E1/2.048MHz outputs. It can expand with up to eight E1/2.048 MHz/T1 outputs programmable on a per port basis.

Applications

The TimeSource 3600 system can be configured as a PRS to front-end an office SSU/SASE or as a stand alone PRS with 10 outputs for remote or small offices. In the stand alone configuration, TimeSource 3600 provides 10 E1/2.048MHz/T1 outputs in a compact, inexpensive package. This configuration is ideal for timing remote switch sites which may also have SDH terminals or other network elements.

The TimeSource 3600 ensures PRS performance is maintained through self-auditing the inputs and measuring and reporting performance against one another. Inputs can be easily provisioned to be either included in the timing ensemble output or be used for monitoring only. TimeSource 3600 is fully software upgradeable and provisionable while in-service. Communications is via RS-232 or Ethernet ports.

TimeSource 3600

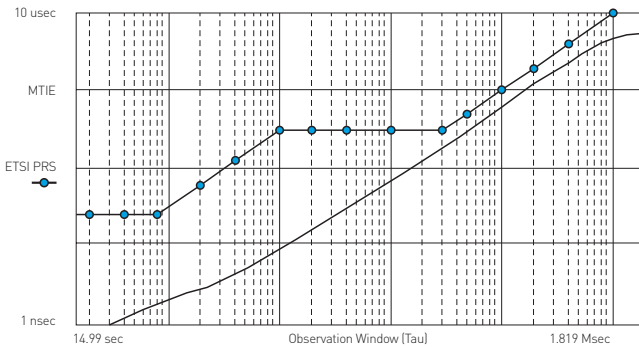

TimeSource 3600 three week PRS quality holdover (@ 25°C)

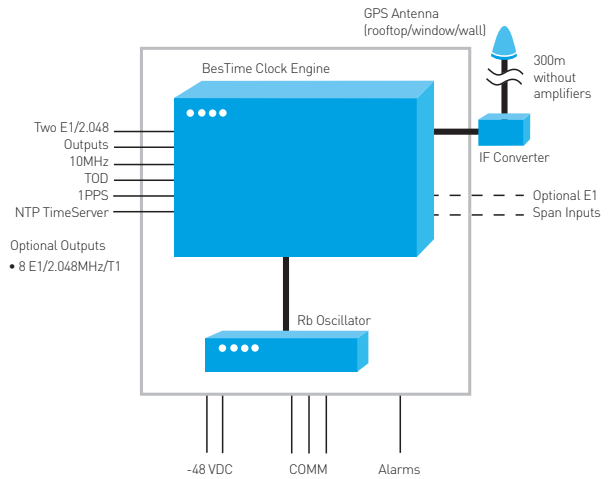

TimeSource 3600 Block Diagram

Specifications

GENERAL

Specifications: ITU-T G.811 and G.812, EN 300 462-6-1, ETSI 3017, CE

Internal oscillator: Rubidium

Sync inputs: GPS; and E1/2.048 MHz

Sync outputs: E1/2.048MHz, 10MHz, 1 PPS, Time of Day, E1 Synchronous Clock Insertion Unit, T1

Sync status messaging: Outputs and inputs

Communications: RS-232, Ethernet

Management: TimeScan/Craft, TimeScan/NMS, TimePictra

SYSTEM OUTPUTS

Number of E1/2.048MHz outputs: Up to 10 (2 standard)

Format: 2.048 Mb/s G.703/9 (CCS, CAS, CRC4, or non-CRC4 configurable) and 2.048 MHz G.703/13 — software selectable

Number of T1 outputs: 8

Format: D4, ESF with or without SSM — software selectable

Frequency accuracy:

Locked to GPS: 1×10^{-12}

Holdover*: 1×10^{-11} for 72 hours (0 to 50° C $\pm 5^\circ$ C)
 1×10^{-11} for 3 weeks at 25° C (typical performance)
 1×10^{-10} for 30 days (0 to 50° C $\pm 5^\circ$ C)

1 PPS OUTPUT

Number of outputs: 1

Signal type: TTL

Connector: BNC

Timing accuracy:

Locked to GPS: 100 ns to GPS

Holdover*: <3.0 μ s to GPS for 72 hours (0 to 50° C $\pm 5^\circ$ C)

TIME OF DAY OUTPUT

Type: Cisco or NTP type 4

Signal: RS-422

Connector: RJ-45

* After 1 week of steady-state operation

NTP TIMESERVER (OPTIONAL)

Type: SNTP

Interface: Ethernet

SYSTEM INPUTS

Number: 2
 Signal: E1/2.048MHz (G.703/9 and G.703/13 software selectable), bridged or terminated
 Connectors: Wire wrap or BNC

ANTENNA SPECIFICATIONS

Type: Wall or window mount patch; Rooftop

Cable length: Up to 300 metres without amplifier

OTHER

Mechanical: 22 cm (H) x 45 cm (W) x 25 cm (D)

Power: -48 VDC (redundant)

Operating temperature: 0° C to +50° C

Humidity: 5% to 95% non-condensing

EMC: CE