

LIGHTNING ARRESTORS FOR GPS SYSTEMS

Product Information

58538A

Lightning Arrestor

58539A

GPS L1 Lightning Arrestor

Lightning can damage GPS system components and receiving equipment, even without a direct hit. This can result in costly repairs and critical interruption of service. The 58538A Lightning Arrestor and 58539A GPS L1 Lightning Arrestor are designed to work in conjunction with a low-resistance, low-inductance ground to protect your GPS receiver and elements of the antenna system from lightning discharges and field-induced electrical surges.



Symmetricom 58538A

The 58538A is a small, waterproof unit designed to operate in the communications band up to 2.5 GHz, and to take much of the energy out of a nearby lightning strike. This unit is typically installed in a grounding panel where the antenna cable enters the building. The 58538A will protect receiving equipment only, and must be used in conjunction with the 58539A.

Symmetricom 58539A

The 58539A is a larger package optimized for use in the GPS L1 frequency range. It will reduce the energy from a nearby lightning strike to a level where it will not harm either antenna system components or receiving equipment. The 58539A may be used alone or with the 58538A, as described in the following paragraphs.

Protect Antenna, Receiver, or Both

With the 58538A and 58539A, you can configure your system to protect the antenna and nearby components only, the receiving equipment only, or both. Your system can also be set up in the recommended configuration or in a more economical configuration.

Protect Antenna and Nearby Components Only

When placed close to the GPS antenna, the 58539A will protect the antenna from surge voltages and currents that can be induced in the antenna cable by lightning. Antenna system components, such as line amplifiers, will also be protected if located between the antenna and the arrestor. Protection of receiving equipment is discussed in the following paragraph.

Protect Receiving Equipment with a Recommended or Economical Configuration

In systems with short in-building cable lengths (<4 m), a single 58539A installed where the antenna cable enters the building is sufficient to protect downstream equipment. Systems with long in-building cables need one 58539A at the entrance to the building and one near the receiver. This diverts to ground any voltages induced in the in-building cable by the electromagnetic fields generated by the lightning strike. For a more cost-effective solution, the 58538A can replace the 58539A at the building entrance, as long as an 58539A is placed near the equipment.

Protect Both Antenna and Equipment

Your GPS system can be configured to protect the antenna and nearby components as well as receiving equipment. Such systems require one 58539A installed properly near the antenna. A second 58539A (or 58538A, as needed) is required at the cable entrance into the building to protect downstream equipment. Finally, a third 58539A should be placed near receiving equipment if the in-building cable run is greater than 4 meters.

Low Maintenance Cost due to Replaceable Surge Arrestor Capsule

Both the 58538A and the 58539A have integrated gas-filled surge arrestor capsules. During lightning strikes, the capsules can direct a single 40 kA current impulse or multiple 20 kA impulses to ground without being destroyed. Periodic replacement of the capsules ensures that the arrestors are performing at their best. There are many other products with gas-capsule technology which do not have replaceable capsules. This makes periodic maintenance expensive because the whole arrestor must be exchanged. Replacement capsules are offered as Option 001.

Durable and Easy to Install

The 58538A and 58539A are designed for easy installation in either indoor or outdoor locations. Both arrestors are waterproof and corrosion resistant, and both feature sturdy Type-N connectors. The 58538A can be mounted directly into a grounding panel. The 58539A has built-in mounting holes for mounting to a flat surface. Option 002 provides a low-resistance, low-inductance, 300-mm grounding cable to the 58539A. Longer cables may not provide proper grounding due to increased resistance and inductance.

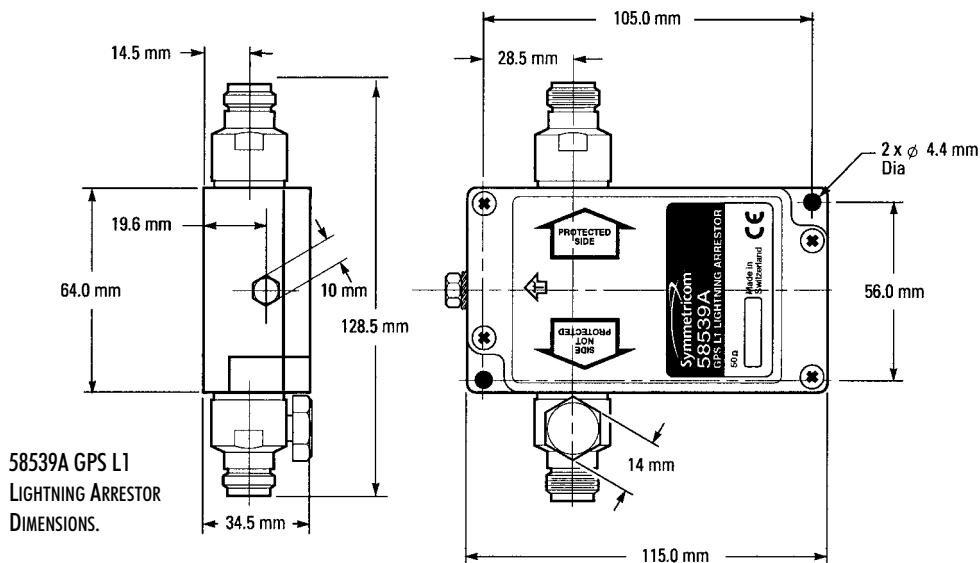
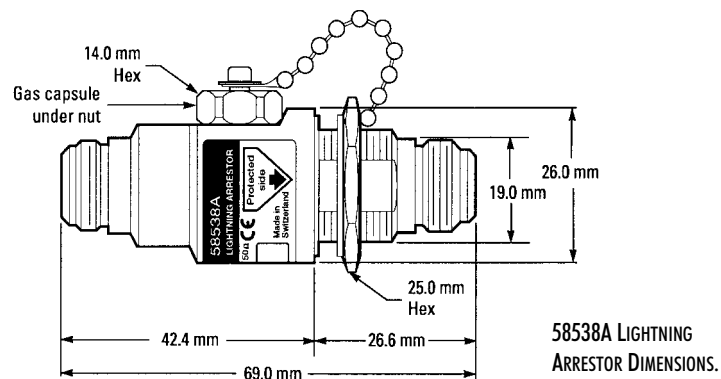

Table 1. 58538A Lightning Arrestor Specifications

| ELECTRICAL | | |
|------------------------------|--|---|
| Frequency range | dc –2.5 GHz | |
| Impedance | 50 Ω (typical) | |
| VSWR | ≤ 1.2 | |
| Insertion loss | ≤ 0.2 dB (typical) | |
| Surge pulse resistivity | 25 kA (8/20 μ s current pulse) | |
| Residual pulse amplitude | < 900 V | |
| PHYSICAL | | |
| Connectors | 2 type-N jacks | |
| Weight | 136 g | |
| Dimensions | 68.3 mm L \times 26 mm W | |
| Panel thickness (See Note 1) | 10 mm | |
| ENVIRONMENTAL | | |
| Operating temperature | -40°C to $+100^{\circ}\text{C}$ | |
| Waterproof | IP 66 (according to IEC 529) | |
| Corrosion | Saltspray test according to MIL-STD-202, Method 101, Condition B | |
| MATERIAL DATA | | |
| Component Part | Material | Surface Treatment |
| Body | Brass, annealed | Tri-Metallization Plating (See Note 2) |
| Soft copper washer | Tellurium copper | Nickel |
| Insulators | PTFE | – |
| Contact pins and sockets | Beryllium copper hardened, HV 350 | Gold plated, MIL-G-45204 Type II, Class 2 |
| Gasket | Silicone rubber | – |

- Note 1. Panel thickness refers to the thickness of the bulkhead grounding panel, should the arrestor be secured to one.
- Note 2. The plating material Tri-Metallization Plating is a copper alloy composed of three components: copper, tin, and zinc. Tri-Metallization Plating complies with the requirements of MIL-C-3902 and CECC 22120. Withstands saltspray test IEC68-2-11.

Table 1. 58539A Lightning Arrestor Specifications

| ELECTRICAL | | |
|------------------------------|---|--|
| Frequency range | GPS L1 (1,565 to 1,586 MHz) | |
| Impedance | 50 Ω (typical) | |
| VSWR | ≤ 1.2 | |
| Insertion loss | ≤ 0.5 dB (typical) | |
| Surge pulse resistivity | 25 kA (8/20 μ s current pulse) | |
| Residual pulse amplitude | < 40 V | |
| Max. bypass voltage | 15 V | |
| Max. bypass current | 1 A | |
| dc bypass resistance | $< 1 \Omega$ | |
| PHYSICAL | | |
| Connectors | 2 type-N jacks | |
| Weight | 449 g | |
| Dimensions | 115 mm L \times 128.5 mm W \times 34.5 mm H | |
| Grounding terminal | M6, recommended wire size: 16 mm ² | |
| Option 002: | 16 mm ² stranded wire cable 300 mm length wire lugs at both cable ends | |
| ENVIRONMENTAL | | |
| Operating temperature | -40°C to $+85^{\circ}\text{C}$ | |
| Waterproof | IP 66 (according to IEC 529) | |
| Corrosion | Saltspray test according to MIL-STD-202, Method 101, Condition B | |
| MATERIAL DATA | | |
| <i>Component Part</i> | <i>Material</i> | <i>Surface Treatment</i> |
| Housing | Aluminum alloy | Chromatized, powder-coat RAL 7035 (gray-white) |
| Connector bodies, outer body | Brass, annealed | Tri-Metallization Plating (See Note 1) |
| Insulators | PTFE | — |
| Contact pins and sockets | Beryllium copper hardened, HV 350 | Gold plated, MIL-G-45204 Type II, Class 2 |
| Gaskets | Silicone rubber | — |

Note 1. The plating material Tri-Metallization Plating is a copper alloy composed of three components: copper, tin, and zinc. Tri-Metallization Plating complies with the requirements of MIL-C-3902 and CECC 22120. Withstands saltspray test IEC68-2-11.

ORDERING INFORMATION (CONTACT SYMMETRICOM FOR PRICING AND AVAILABILITY)

58538A Lightning Arrestor

Option 001 Replacement Capsule

58539A GPS L1 Lightning Arrestor

Option 001 Replacement Capsule

Option 002 Grounding Cable

For more information

Dependable Accessories for Your GPS Installation—Brochure

Designing Your GPS Antenna System—Configuration Guide.



Symmetricom
2300 Orchard Parkway
San Jose, CA 95131, USA
tel: 408-433-0910
fax: 408-428-7897
e-mail: info@symmetricom.com
<http://www.symmetricom.com>

Symmetricom Limited
2 The Billings
Walnut Tree Close
Guildford, Surrey
GU1 4UL, England
tel: 44-1483-510300
fax: 44-1483-510319

©2000 Symmetricom
Specifications subject to change without notice.
DS/58538A-39A/D/0200/2M