



TimeHub 5500

NEBS Level 3 Certified Building Integrated Timing Supply for Carrier-Class Networks

KEY FEATURES

- Next Generation Building Integrated Timing Supply
- Packet Timing Solutions for NGN Applications
- Carrier-Class NTP Integration
- IEEE 1588 Precision Time Protocol Grandmaster Server Blades
- Supports all Physical Layer Synchronization Requirements
- More than 1400 Protected Outputs per System
- Single Output Card Generates CC and DS1 Signals
- Full SSM Support
- Master or Remote Shelf Operation
- NEBS Level 3 Certified

The TimeHub™ 5500 is the next generation Building Integrated Timing Supply (BITS) designed for carrier-class networks. TimeHub is an NGN ready platform designed to meet all traditional central office synchronization and timing requirements. It provides next generation packet timing solutions critical to advanced service offerings such as IPTV and wireless backhaul. Already deployed as the workhorse for major fiber deployments in North America, the TimeHub 5500 is the platform of choice for delivery of carrier-class NTP and IEEE 1588 Precision Time Protocol (PTP) required to assure high QoS delivery of NGN applications and content.

THE TIMEHUB SYSTEM

Explosive growth in telecommunication volume, especially in video and data, has led to new technologies and critical applications. Service providers are growing to meet this demand. As a result, the requirements for synchronization have changed dramatically.

Symmetricom's TimeHub 5500 is the next generation BITS. It is a modular,

fully redundant timing distribution system that tracks incoming timing references and qualifies the signals against network timing standards. Then, it filters and distributes precise timing to all equipment in the central office.

The TimeHub main shelf provides up to 140 1+1 protected outputs. If more outputs are required, up to four expansion shelves can be connected to the main shelf, increasing the capacity to over 1,400 fully protected 1+1 ports per system.

MANAGEMENT AND ALARM COLLECTION

The TimeHub system provides a new dimension in management by integrating and monitoring the performance of legacy equipment.

As an intelligent network element, TimeHub provides full visibility and manageability of all input and output ports and all cards on the main and expansion shelves. System parameters can be modified and controlled through any of its multiple interfaces—serial and Ethernet.



TimeHub 5500 with Expansion Shelf

MONITORING INPUTS

The ability to monitor multiple inputs allows performance measurement of existing local and remote BITS or any DS1 line. Up to eight DS1 and one 5 or 10 MHz inputs can be monitored simultaneously and their results sent to the NOC. This helps ensure that legacy BITS meet carrier-class standards for reliability and compatibility with existing central office equipment.

INPUT AND CLOCK CARDS

The input and clock cards are combined in a single card with a highly stable clock engine. Each card accepts four DS1 inputs and one selectable 5 or 10 MHz input, plus four additional DS1 inputs for monitoring purposes only.

The cards are available in either rubidium or quartz versions. The Stratum 2 and Stratum 3E clocks exceed the minimum specification requirements during holdover.

SMARTCLOCK TECHNOLOGY

SmartClock™ technology improves the performance and accuracy of the clocks. Using intelligent firmware algorithms, SmartClock “learns” the effects of aging and temperature on the clock while it is locked to the reference signal and stores this information. When the incoming reference signals are lost or disqualified, SmartClock uses the stored data to compensate for frequency changes during holdover.

The system will continue to distribute highly stable synchronization signals while predicting and correcting the behavior of the oscillators until input reference signals are restored. SmartClock provides a superior level of synchronization and timing stability during holdover that other methods cannot achieve.



TimeHub Master Shelf shown with Carrier-Class NTP Server Cards in Output Group D

CARRIER-CLASS IEEE 1588 BLADES

With the introduction of high-performance IEEE 1588 PTP Grandmaster Server Blades, the TimeHub platform can now deliver carrier-class PTP to meet demanding NGN packet timing requirements. IEEE 1588 Blades for the TimeHub provide the performance, scale, availability and security to deliver carrier-class synchronization to remote PTP clients in wireless basestations or remote terminals over Ethernet networks.

Symmetricom’s IEEE 1588 Blades are fully integrated into the TimeHub system. These cards can be installed as single servers or redundant pairs in any available master or expansion shelf output slot. PTP capacity scales up at a rate of up to 125 full rate clients per card. Front-access IEEE 1588 traffic ports utilize Small Form-factor Pluggable (SFP) modules for flexibility to support 100 BaseT electrical or 1000 Base-X optical or electrical interfaces. All configuration and management is consolidated through TimeHub system management ports to maintain security and isolation from IEEE 1588 ports.

CARRIER-CLASS NTP CARDS

NTP requirements in telecommunication networks have rapidly evolved from a “best effort” utility, to a mission critical requirement for high QoS content delivery. TimeHub’s carrier-class NTP cards utilize advanced hardware based time stamping to provide 10 nanosecond

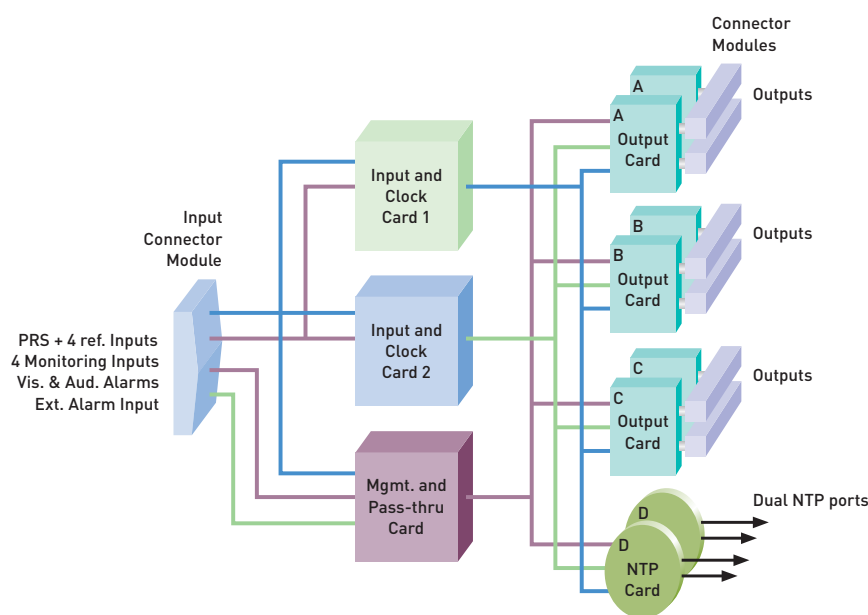

FIG 1: TimeHub 5500 Architecture

accuracy—orders of magnitude better than enterprise class NTP servers. Each dual port NTP card supports up to 1500 transactions per second for high capacity loading applications. The system scales up for mass deployment scenarios with an additional 1500 NTP transaction per second for each additional NTP card.

NTP cards can be installed as standalone servers or as redundantly protected pairs. Small Form-factor Pluggable (SFP) modules provide flexibility to support 100/1000 Base-T electrical or 1000 Base-X optical interfaces. All configuration and management is provided through TimeHub system management ports to maintain security and isolation from the NTP traffic ports.

OUTPUT CARDS

Each of the TimeHub output cards provides 40 outputs. The outputs are split in two groups of 20 outputs each. Depending on passive connector modules plugged in the back of the shelf, each group can provide 20 DS1 or CC output signals. The output cards recognize the connector modules and automatically switch each group to the appropriate signal type.

Output modules can be mixed in any combination to provide DS1 and CC output signals from the same card group. This unique feature adds flexibility to the TimeHub system, minimizing inventory costs and simplifying planning and maintenance of the synchronization network.

PROTECTED OUTPUTS

TimeHub 1+1 is a truly hitless protection scheme. Unlike 1:n protection schemes where only one card provides output signals at a time, in the TimeHub 1+1 scheme, both output cards remain active. If a card fails or is removed, the mate card is already providing a signal to the network elements. No time is lost waiting for a stand-by card to recognize a failure before it becomes active. The result is a clean, hitless timing signal no other protection scheme can offer.

EXPANSION SHELF

When 140 ports are not enough, TimeHub offers additional outputs via its expansion shelves. Each of the four additional expansion shelves can provide up to 320 protected outputs, making it the expansion shelf with the highest

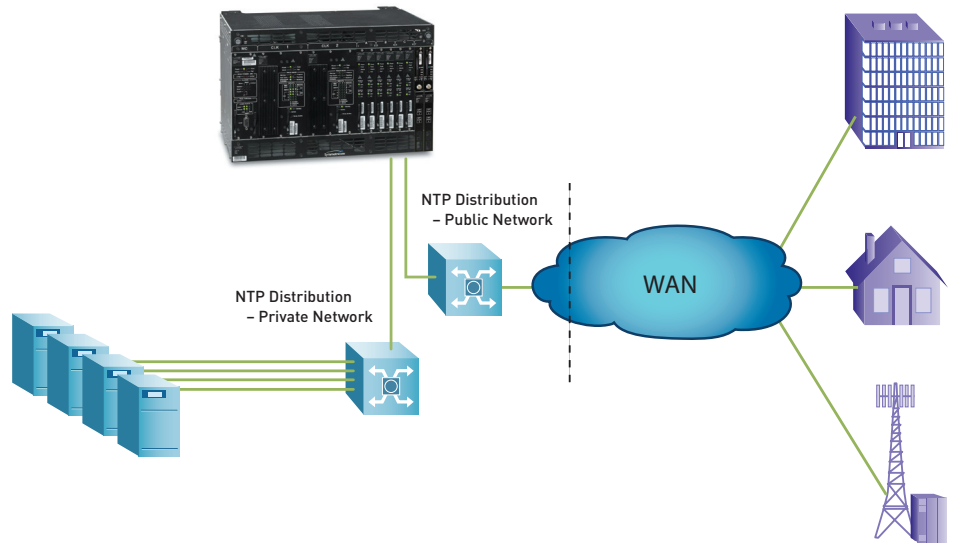

FIG 2: NTP Server cards make it easy to isolate and secure Private network NTP distribution from Public network NTP distribution.



TimeHub Expansion Shelf shown with Carrier-Class NTP Server Cards in Output Groups G and H

output capacity on the market. All communication and alarms are managed by the TimeHub Master shelf through redundant expansion link cabling.

MASTER OR REMOTE

A remote shelf makes it possible to synchronize network equipment located on multiple floors or in other buildings within large central office facilities, while maintaining phase alignment with a master synchronization system. A unique TimeHub feature allows utilizing the same master shelf and cards as a remote system. This reduces inventory costs and simplifies the transition from master to remote shelves when expanding or upgrading central offices.

By setting a switch on the main shelf to operate as a remote system, intelligent algorithms in the management and clock cards modify their operation by adjusting their parameters and electronics to operate as a remote system.

The ST2 and ST3E clock cards will align in phase to the active CC input signal. Upon losing the CC reference signals, the intelligent clocks will provide ST2 or ST3E holdover performance preventing data slips for hours or days. This proprietary TimeHub feature gives the maintenance crew additional time to troubleshoot network problems, while ensuring the network continues to provide carrier-class Quality of Service.

TimeHub remote shelves can also operate in conjunction with existing BITS. Carriers can enhance older BITS systems with state-of-the-art synchronization technology, while maximizing the value of their investment in legacy technology.

SSM SUPPORT

Synchronization Status Message (SSM) is a useful tool for monitoring and maintaining the health of the synchronization network. Master, expansion and remote TimeHub products support the latest SSM messages.

SYSTEM UPDATE

To keep the TimeHub Master and Remote systems with the latest features and standard recommendations, software can be easily downloaded.

Via the Ethernet connection, maintenance personnel can remotely download Firmware into the system in

minutes. This saves time and avoids sending a maintenance crew to the site to replace cards.

CONNECTIVITY

TimeHub offers serial and Ethernet connectivity. Multiple TCP/IP sessions allow NOC personnel as well as local maintenance people to access the system. Symmetricom’s network element management system, TimePictra™, provides visibility of all TimeHub, TimeSource® and third-party network elements in the network.

NEBS LEVEL 3 CERTIFICATION

Symmetricom’s TimeHub system is Network Equipment Building System (NEBS) Level 3 certified. This ensures all TimeHub components meet carrier-class standards for safety, reliability and compatibility with the customer’s existing equipment.

APPLICATIONS

The TimeHub 5500 system was designed for critical applications where network elements require truly hitless timing, flexibility and growth capability for NGN physical layer synchronization requirements as well as application and management layer packet timing requirements.

Legacy Symmetricom or third-party synchronization equipment can easily be upgraded by front- or back-ending them with TimeHub systems. The TimeHub will collect the alarms and monitor their performance, while integrating them into a management environment.

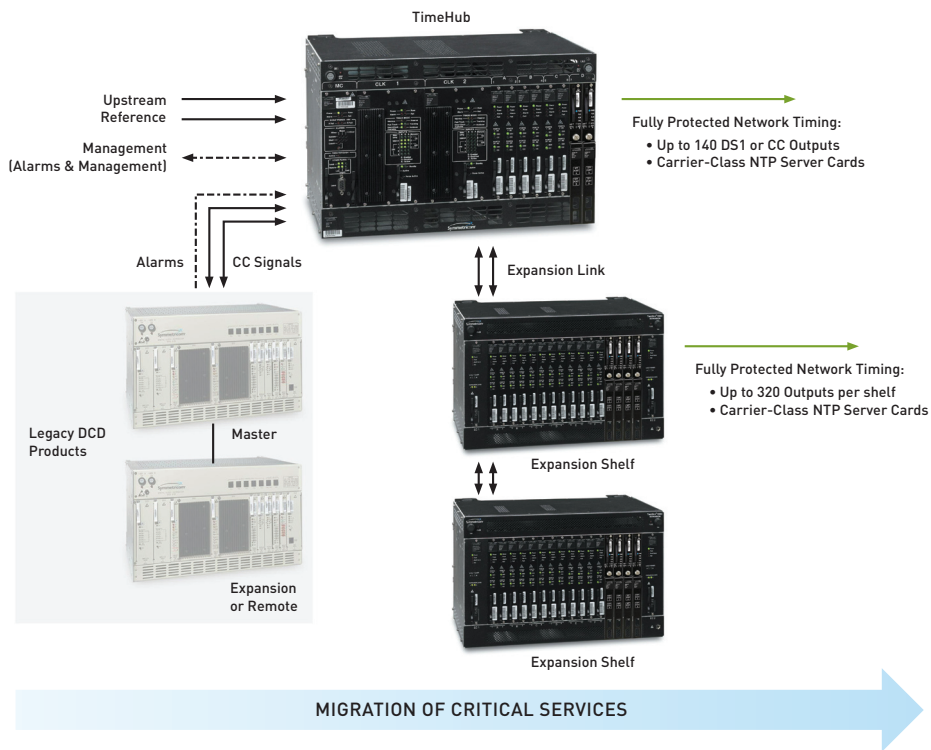

FIG 3: High capacity TimeHub system easily supports NGN network growth, and migration of legacy services.

SPECIFICATIONS

MASTER SHELF

- Reference and monitoring inputs: 4 DS1 (1.544 Mb/s) 1 5/10 MHz (selectable)
- Phase alignment input: 1 CC (64 kbps)
- Additional monitoring inputs: 4 DS1 (1.544 Mb/s)
- Input framing: D4 or ESF (selectable)

REMOTE SHELF

- Reference inputs: 2 CC (64 kbps)
- Auxiliary SSM inputs: 2 DS1 (1.544 Mb/s)

MASTER AND REMOTE SHELVES

- Clock types:
 - ST2: Rubidium based, 9 inputs
 - ST3E: Quartz based, 9 inputs
- Holdover stability:
 - ST2: Typically better than 1×10^{-11} in 24h (25°C)
 - Exceeds GR-1244 for ST2 clocks
 - ST3E: Typically better than 1×10^{-10} in 24h (25°C)
 - Exceeds GR-1244 for ST3E clocks
- Clock control: Direct Digital Synthesis (DDS) with SmartClock technology
- Output capacity: Up to 140 protected (1+1) or unprotected outputs
- Expansion: Up to 4 expansion shelves per Master or Remote

EXPANSION SHELF

- Output capacity: Up to 320 protected (1+1) or unprotected outputs
- Redundancy: 2 Identical links to main shelf, 2 Identical controller cards

IEEE 1588 PTP GRANDMASTER SERVER CARDS

NETWORK PROTOCOL

- IEEE 1588-2008: Unicast with dynamic reservations (sec 16.1)
- IPv4 (annex D), IPv6 (future)

PTP CAPACITY

- Up to 125 PTP clients at full rate per the IEEE 1588-2008 Telecom Profile

SERVER PRECISION

- 10 ns rms typical (one-step, hardware timestamps)

TIME SCALE SUPPORT

- TAI (International Atomic Time), TimeSource PRS required
- Arbitrary Time Scale

PTP TRAFFIC PORT

- One Ethernet Small Form-factor Pluggable (SFP)
 - Optical: 1000 Base-X
 - Electrical: 100 Base-T, 1000 Base-T

VLAN SUPPORT

- 4 VLANs (IEEE 802.1Q)

PROTECTION

- 1:1 protection (full hardware redundancy)

MANAGEMENT

- TL1 and CLI - Integrated into TimeHub system management (physical isolation from PTP traffic ports)

CARRIER-CLASS NTP CARDS

- Network protocol: NTP v3 – RFC1305 compliant IPv4
- Inputs
 - Stratum 1: Time-of-Day feed from TimeSource PRS (RJ 45, RS422 1000 ft) Optional GPS input (12 channel, 50ns rms)
 - Stratum 2: Full NTP client
- Ethernet NTP Traffic ports: 2 Ethernet Small Form-factor Pluggable (SFP)
 - Optical: 1000 Base-X
 - Electrical: 100/1000 Base-T
- NTP Transaction rate: 1000/s fully authenticated (up to 1500/s unauthenticated, uniform distribution)
- Authentication: MD5 (RFC1321)
- Protection: 1:1 protection
- Management: Secure, Out-of-Band (see management and communication)

OUTPUT CARDS

- Outputs per card: 40
- Output signals: DS1 and CC from the same card 40 DS1, 40 CC, or 20 DS1 and 20 CC
- Framing: D4 or ESF, selectable in two groups of 20

ELECTRICAL

- Signals:
 - DS1: GR-499-CORE Line code B8ZS 100Ω balanced, W-W
 - CC: GR-378-CORE Line code bipolar RTZ 133Ω balanced, W-W
 - 5/10 MHz: Sine or square wave 0.5 V_p 50Ω unbalanced, BNC
- Operating voltage: -42V dc to -60V dc
- Current
 - Master, Remote: 6A (max.)
 - Expansion: 4A (max.)

ALARMS

- Severity (audible and visible): Minor, Major, Critical: N.O. and N.C. contacts
- External alarm inputs: 10

MANAGEMENT AND COMMUNICATION

- Communication ports: 1 Serial RS-232 1 Ethernet connection (10 Base-T)
- Connector: 2 DB-9F (front and rear) 1 RJ-45 in the rear
- Baud rate: 1200, 2400, 9600, 19200
- Sessions: Up to 10 simultaneous TCP/IP sessions
- Storage capacity: Over 1,000 events

GENERAL

- SSM: Compliant with SSM specifications per T1X1.3 TR-33, Telcordia GR-253-CORE and GR-378-CORE
- Operating temperature: 0°C to 50°C (32°F to 122°F)
- Operating humidity: 5% to 95%
- Shelf dimensions mm (in.): 267 H x 422 W x 295 D (10.5" H x 16.6" W x 11.6" D)
- Certifications: NEBS Level 3 certified (MET labs) SBC TP-76200MP Telcordia